



VACUUM DEGASSER

VIRADEG USER MANUAL



User Manual - 3.3

ENGLISH

1) PREFACE PAGE	
1.1) Symbols	4
1.2) Scope of delivery	4
2) INTRODUCTION	
2.1) Overview of the units	5
2.1.1) Overview of V3	5
2.1.2) Overview of V6	6
2.2) Operation	7-8
2.2.1) General	8
2.2.2) Refilling	8
2.3) Operating Conditions	8
3) TECHNICAL SPECIFICATIONS	
3.1) Dimensions	9
3.2) General Specifications	10
3.3) Suggestions	10
4) SAFETY	
4.1) General Precautions	11
4.2) Type Plate	11
5) INSTALLATION AND COMMISSIONING	
5.1) Installation conditions	12
5.2) Installation and mounting	12
5.2.1) Wall mounting	12
5.3) Mechanical	13
5.4) Electrical	14
5.4.1) Building Management System	15
6) START-UP	
6.1) Button Functions	16
6.2) Filling the unit	17
6.3) Settings Parameters	17-18
7) FAILURES	19
8) REMOVING CONTROLLER	20
9) MODBUS FUNCTIONS	21-22
9.1 ViraDeg Modbus Connection	23-27
10) TRANSPORT	28
11) GUARANTEE	29
12) CE STATEMENT	
12.1 Declaration of conformity	29

1. PREFACE

This user manual describes the installation, commission and operation of the VIRADEG V3 and V6.

Read the instructions before installation, commissioning and operation. Keep the instructions for future reference.

This manual has been composed with the utmost care. Should, however, this manual contain any inaccuracies, Vira Inc. cannot be held responsible for this.

This manual describes the installation commissioning and operation of the VIRADEG types :

Type	Product Description
V3	3 bar ViraDeg vacuum degasser
V3 - R	3 bar Auto-refillable ViraDeg vacuum degasser
V6	6 bar ViraDeg vacuum degasser
V6 - R	6 bar Auto-refillable ViraDeg vacuum degasser

1.1 Symbols

Throughout the instructions the following symbols are used ;

	Warning
	Important Note
	Risk Of Electric Shock
	Risk Of Burning

1.2 Scope of delivery

ViraDeg
User Manual
Flex hoses
Unboxing Sheet

2. INTRODUCTION

2.1 Overview of the units

2.1.1 Overview of V3

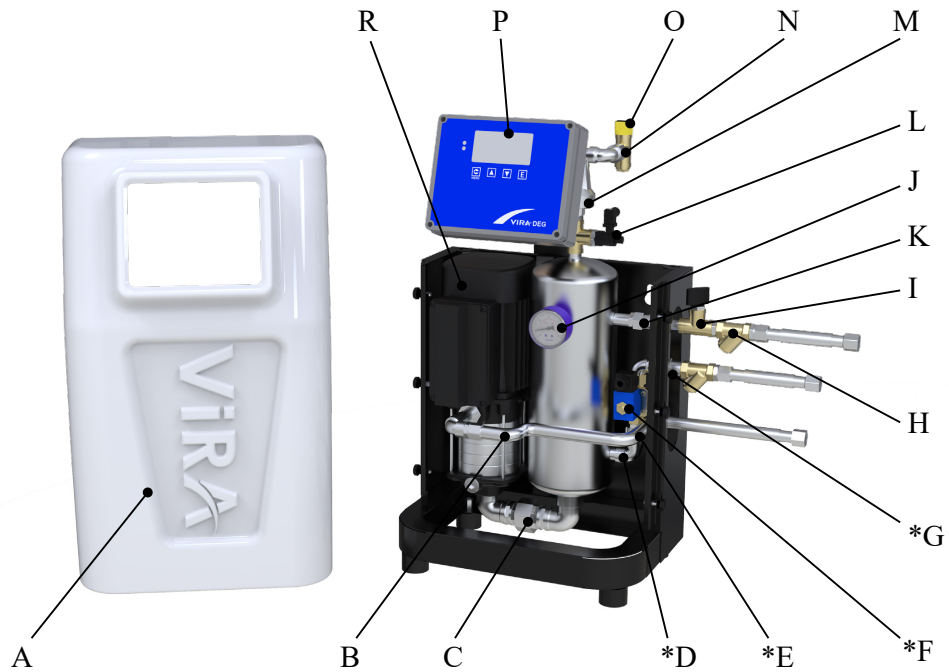

A	Cover
B	Flex Hose
C	Conical Fitting
D	Muff
E	Check Valve
F	Solenoid Valve
G	Flow Limiter
H	Strainer
I	Pressure Sensor

J	Manometer
K	Flow Limiter
L	Pressure Switch
M	Airvent (Viratop)
N	Check Valve
O	Smart Sensor
P	Control Panel
R	Pump

Note : Ass the parts marked with (*) are in the refill line, they are not available in models without refill feature.

2.1.2 Overview of V6

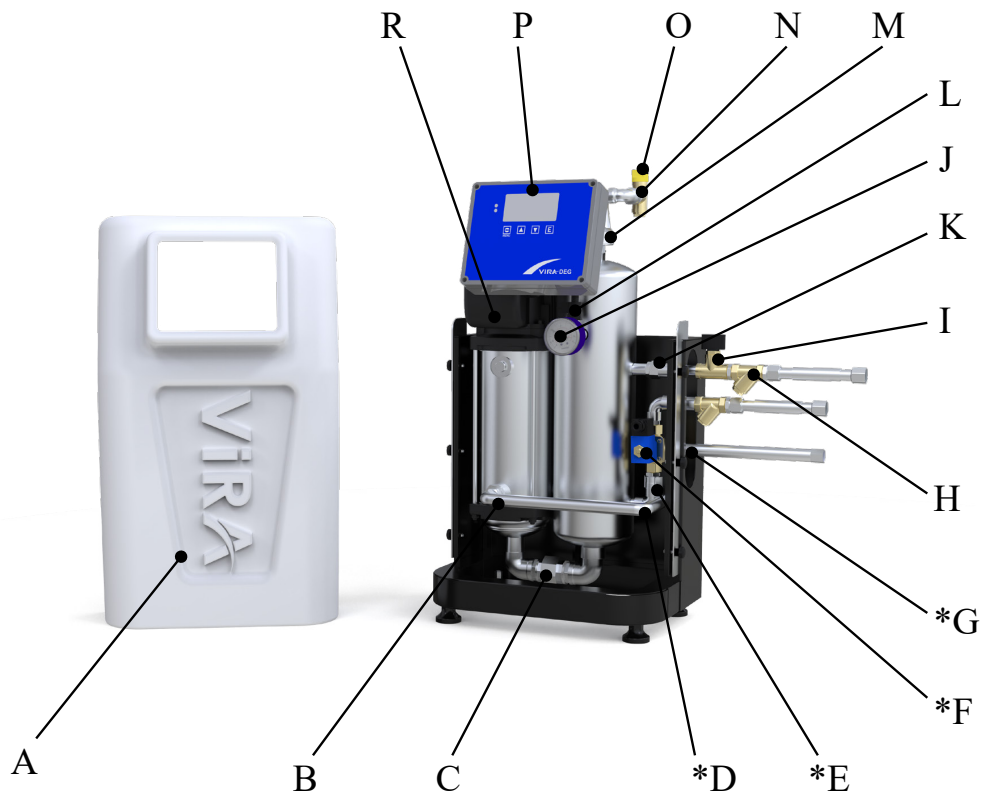

A	Cover
B	Flex Hose
C	Conical Fitting
D	Muff
E	Check Valve
F	Solenoid Valve
G	Flow Limiter
H	Strainer
I	Pressure Sensor

J	Manometer
K	Flow Limiter
L	Pressure Switch
M	Airvent (Viratop)
N	Check Valve
O	Smart Sensor
P	Control Panel
R	Pump

Note : Ass the parts marked with (*) are in the refill line, they are not available in models without refill feature.

2.2 Operation

The figures below schematically show the operation of the unit. The drawings indications correspond with the main figure on the previous pages.

OPERATION OF V3-R

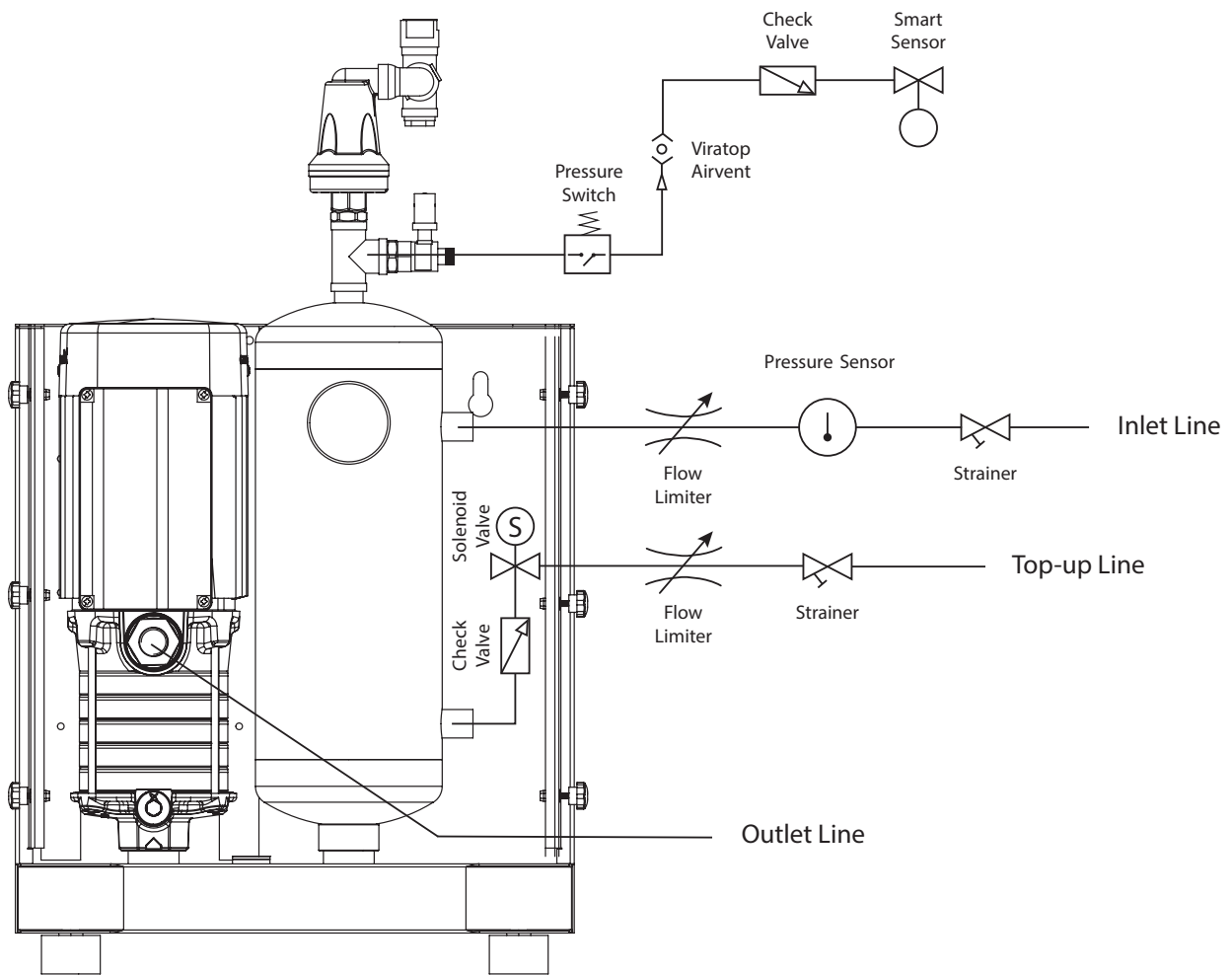

2.2.1 General

The ViraDeg is a fully automatic vacuum degasser for installations filled with fluid. Fluids contain dissolved and free gasses. The unit removes these gases from installation. Problems caused by gases in the installation are thus prevented.

The unit starts up a degassing process each day at a time set by the user. The process has two phases:

1- The rinsing phase : The fluid flows from the installation into the vessel. After the vessel fully filled, the pump works the fluid from the vessel into the installation. Here the fluid absorbs gases present in the installation.

2- The vacuum phase : The running pump provides underpressure in the vessel. The underpressure causes the release of the gases dissolved in the fluid, which are collected at the top of the vessel. The gases are removed from the installation through the automatic air vent. The SmartSwitch at the automatic air vent makes sure that the stopped as soon as the content of dissolved gases has reached the minimum level.

2.2.2 Refilling

The ViraDeg-R models have an integrated refill function.

A unit with a refill function can control the pressure of the installation. To control the pressure, the unit inserts additional degassed fluid into the installation, if necessary. The unit can also fill the entire installation with degassed fluid.

2.3 Operating Conditions

The unit is suitable for use in systems filled with clean water or mixtures of water with maximum of 40% glycol. Use in combination with other fluids may result in irreparable damage.

The unit should be used within the limits of the technical specifications as given in chapter 3.

Warning !



- In case of doubt, always contact the supplier.
- In case of a heavily contaminated system fluid, install a dirt separator or filter in the main return line of installation.

3 TECHNICAL SPECIFICATIONS

3.1 Dimensions

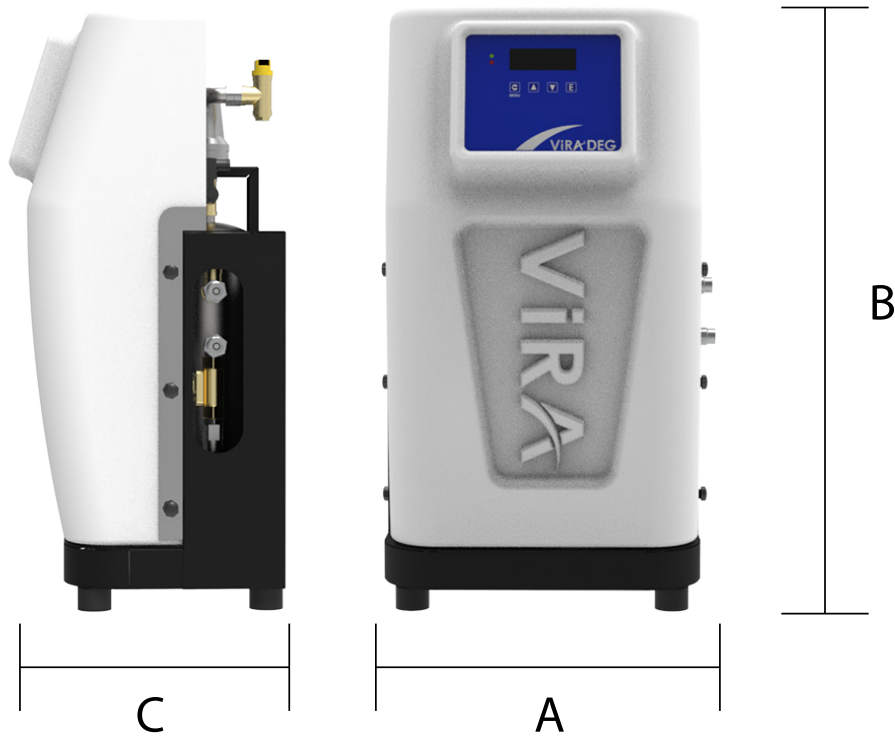

Model	A (mm)	B (mm)	C (mm)
V3	410	740	330
V3-R	410	740	330
V6	410	740	330
V6-R	410	740	330

3.2 General Specifications

Type	V3	V3-R	V6	V6-R
Pump brand	Grundfos	Grundfos	Lowara	Lowara
Max. Pressure	3.8 barg	3.8 barg	6.0 barg	6.0 barg
Empty weight	40	41	50	51
Vessel (stainless)	5.5 lt	5.5 lt	7.0 lt	7.0 lt
Max. Glycol	40%	40%	40%	40%
Connection (inlet/outlet)	1/2" female	1/2" female	1/2" female	1/2" female
Noise level	50 db(A)	50 db(A)	56 db (A)	56 db (A)
Refill connection	-	1/2" female	-	1/2" female
System pressure	0.5 - 3.8 bar	0.5 - 3.8 bar	1.0 - 6 bar	1.0 - 6 bar
Ambient temperature	1 - 55°C	1 - 55°C	1 - 55°C	1 - 55°C
Temperature system fluid	- 20 / 90°C	- 20 / 90°C	- 20 / 90°C	- 20 / 90°C
Refill pressure		0.8 - 10 bar		1 - 10 bar
Temperature refill fluid	1 - 90°C	1 - 90°C	1 - 90°C	1 - 90°C
Refill volume (l/h)	180 l/h	180 l/h	180 l/h	180 l/h
Supply voltage (50-60 Hz)	220-240 V	220-240 V	220-240 V	220-240 V
Power supply	0.67 kW	0.67 kW	0.75 kW	0.75 kW
Nominal current	4.0 - 4.4 A	4.0 - 4.4 A	4.9 A	4.9 A
Capacity (pressure < 2 bar)	600 lt / h	600 lt / h	780 lt / h	780 lt / h
Capacity (pressure > 2 bar)	800 lt / h	800 lt / h	1000 lt / h	1000 lt / h
Protection class	IP 54	IP 54	IP 54	IP 54

3.3 Suggestions

- Strainer on the ViraDeg should be cleaned when needed. Min. 2 times in a year.
 - Interior of solenoid valve should be controlled every year.
 - User should be ensure that each spare part of ViraDeg works properly.
- To be absolutely sure to have an efficient and reliable operation of ViraDeg and your system it is recommended to have skilled personnel to check the unit every 2. Year and have necessary service executed.

4. SAFETY

4.1 General Precautions



- Installation and maintenance of the unit should only be carried out by qualified personnel.



- Remove the power and pressure from the unit before starting activities.
- There are hot parts under the cover. Let the unit cool down before starting the activities.

4.2 Type Plate

Sample label which located on the product.

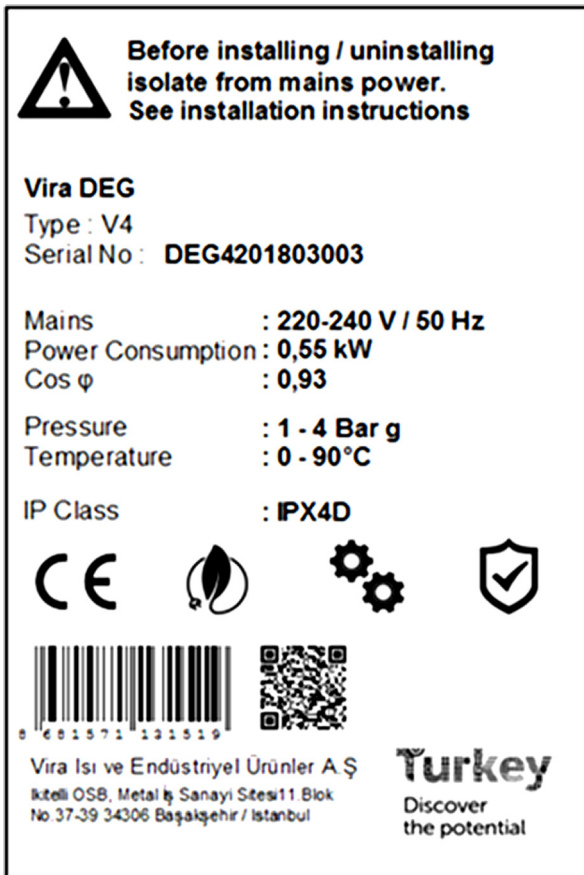

Plate Includes

- Product Type
- Serial Number (You may need this under warranty period)
- Electrical connections
- Energy consumption information
- Pressure and Temperature
- IP Class
- QR Code includes product manual You can use if you lost this guide book. (or visit our website)
- Manufacturer company details

5. INSTALLATION AND COMMISSIONING

5.1 Installation Conditions

- Install the unit on a frost-free, well-ventilated place.
- Connect the unit to a 230 V / 50-60 Hz power supply.
- Make sure that the expansion system has the proper dimensions. The water displacement in the unit can cause pressure variations in the installation. Take into account an extra net expansion volume of at least 8 litres.

5.2 Installation And Mounting

Caution



- Install the unit in accordance with the local guidelines and rules.
- Install the unit as bypass to a main line of installation.
- Preferably install the unit as close as possible to the expansion system.



- Preferably install the unit at the point in the installation with the lowest temperature. Here the most dissolved gases are found in the fluid.
- Install the unit close to the expansion system to minimise pressure fluctuations caused by the intake of water by the system.
- Make sure that the operating panel is always easily accessible.
- Make sure that you maintain at least the distance for service and repair as indicated. (300 mm for each connection)

5.2.1 Wall Mounting

Mount the unit on the wall by using the holes (A).
Make sure that the mounting can support the filled unit.

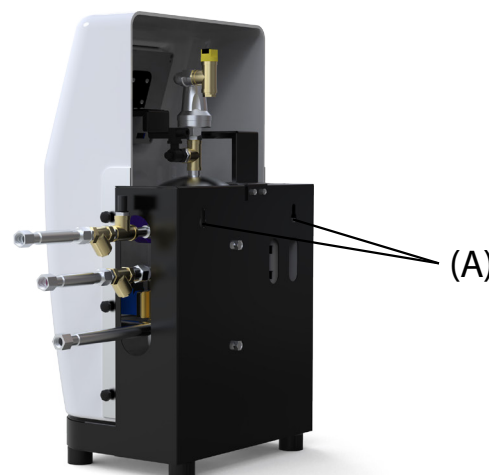

5.3 Mechanical

1. Make two branch lines 1/2" (A) on the side of the main transport line. The distance pay attention to A and C connection distance should be at least 500 mm.

2. Insert a valve (A and C line) in each branch. With these valves the unit can be isolated.

Caution



- Make sure that the valves are opened before putting the unit into operation.



- As seen the direction of the volume flow, the first branch is the inlet of the unit.

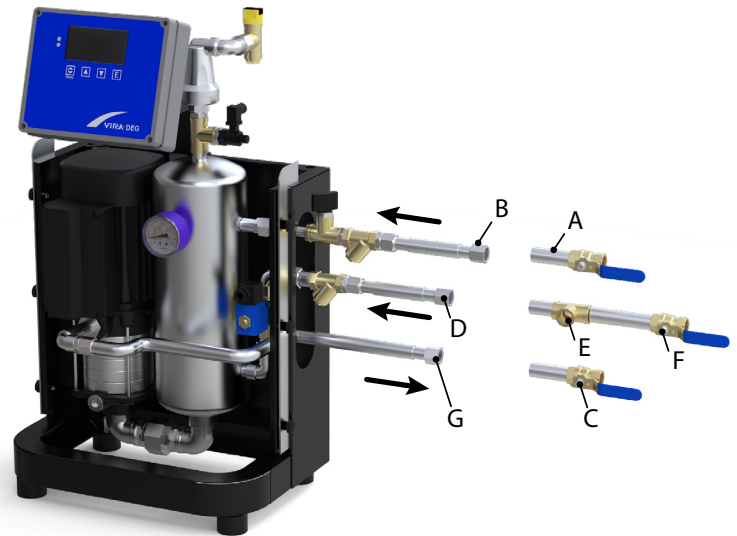

3. Connect the line (A) to the flexible outlet line (B)
Connect the line (C) to the flexible outlet line (G)

Only applicable to unites with the refill functionality ;

1. Insert a valve (F) and a backflow protection (E) in the refill fluid supply line.



- Use locally approved backflow protection. A backflow protection can also be supplied as an option with the unit.
- Make sure that the pressure of the feedwater is below the system pressure.
- Make sure that the lines leave the unit at the rear.

2. Connect the make up water to the refill connection (D) of the unit.

5.4 Electrical

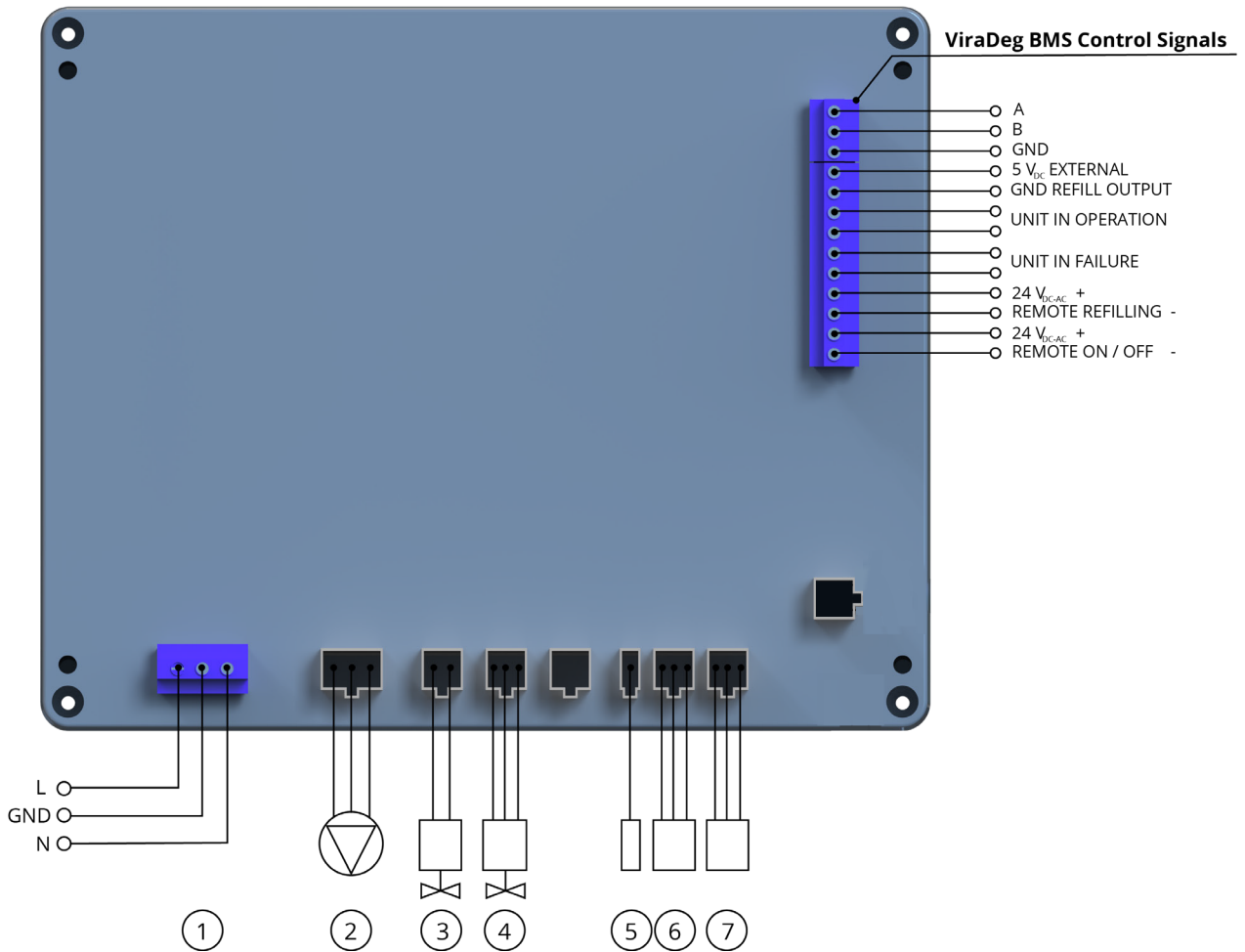

1. Mains Electricity (230V/50Hz)

L : Line , N : Neutral ,GND: Ground

2.Pump

3.Refill Solenoid Valve

6.P.SW : Pressure Switch

7. Air S : Air low Switch

8. P/T S: Pressure and Temperature Sensor

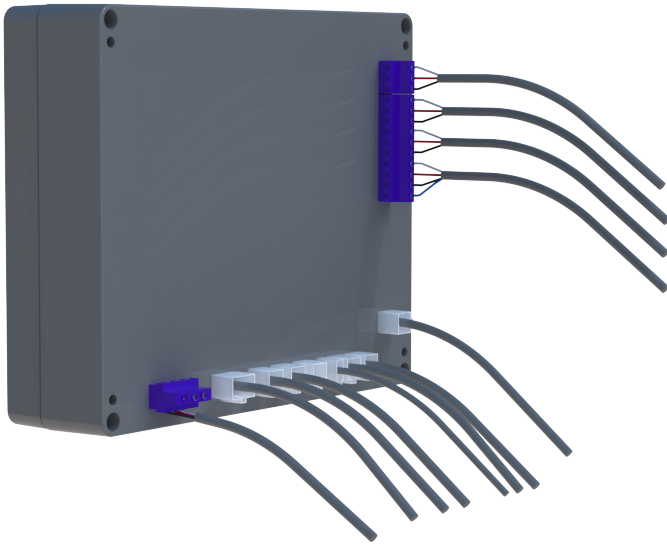

- There are cable connections on the control panel. These connection points are only used to fix the cables.

- Please do not try to pull cable out.



- Please check chapter 8 to remove the controller.

5.4.1 Building Management System (BMS Control Signals)

The unit is provided with auxiliary contacts for communication with a BMS or other external system.

The BMS must offer a 24Vac voltage.

The failure signal must not be used as a boiler interlock.

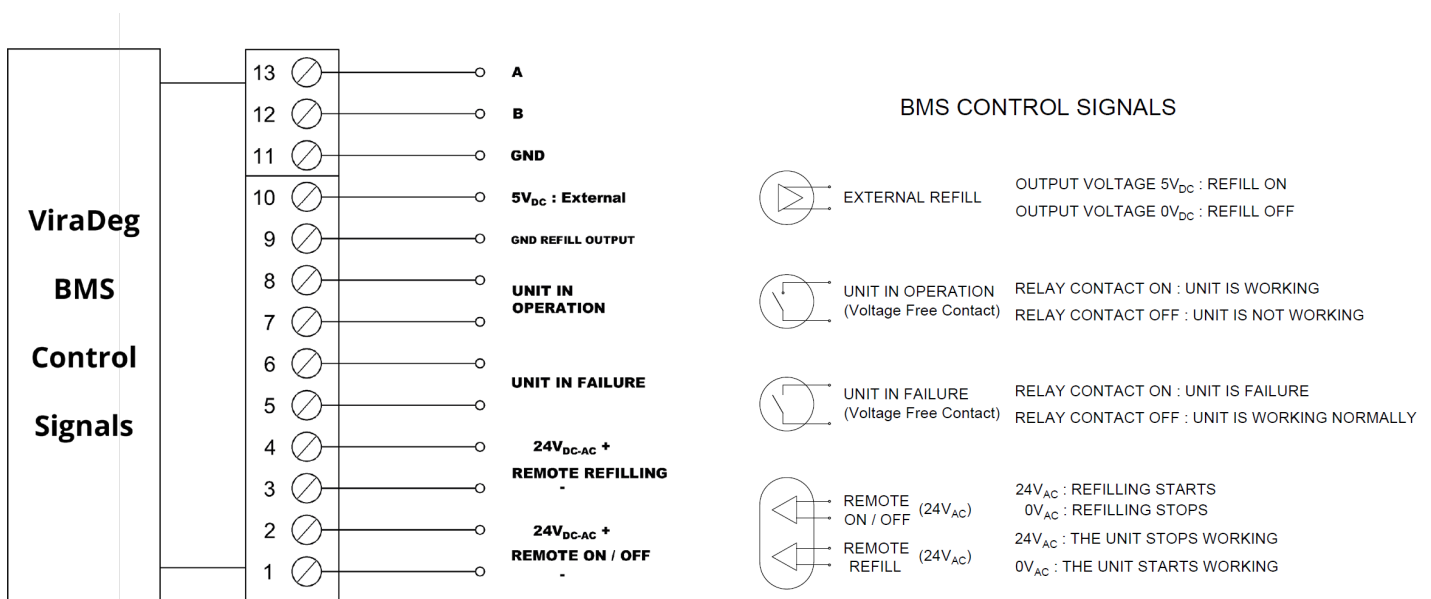

6. START-UP

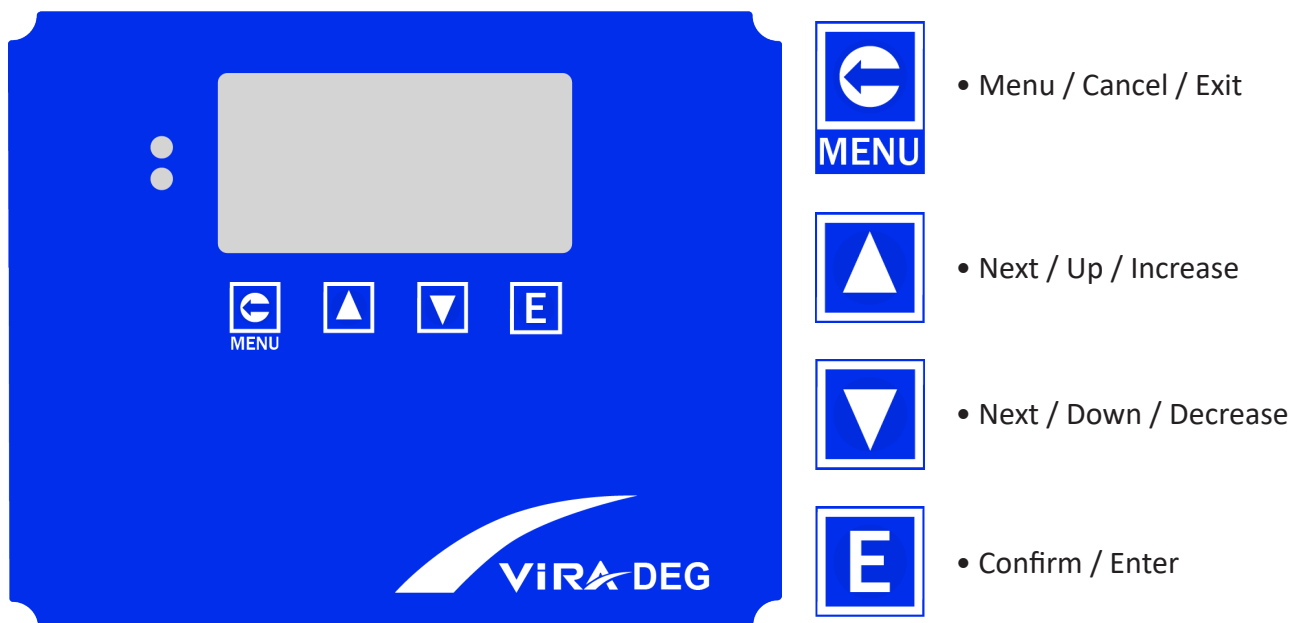

6.1 Button Functions



Menu button is only used to enter the main menu and return the previous menu.



Button is used to pass to next function in the menu and to change numerical values.



Button is used to pass to before function in the menu and to change numerical values.



Button is used to enter the any menu, submenus and to confirm the values after change sets.

Caution



- The start-up routine starts automatically when the unit is switched on for the first time.
- Press Menu to edit settings according to you.

6.2 Filling The Unit

- It is very important to get water into the system by opening the inlet valve slightly while filling/starting the product. After the tube is completely filled with water and the pressure is seen on the manometer, the inlet valve can be fully opened.
- Likewise, in order to prevent air entrapment, it is necessary to loosen the air holes in the pump.
- System will be off in first energy applied. At this time, user should edit the settings. (Time, Date, Working hours etc.)
- Turn the system on in the menu then ViraDeg will be started.
- Shortly after the product starts to work, the vent holes of the pump are closed and the system continues to operate automatically.

6.3 Setting Parameters

MAIN MENU

SYSTEM ON/OFF>>		TO SELECT THE SYSTEM ON OR OFF
<SYS.ON/OFF SELECT>		SYSTEM ON/OFF SELECT
	(SYSTEM ON)	SYSTEM IS SWITCHED ON
	(SYSTEM OFF)	SYSTEM IS SWITCHED OFF
MANUEL OPR.>>		MANUEL OPERASYON
Manuel Run >		SYSTEM RUNS CONTINUOUSLY,
Manuel Refilling >		THE REFILLING IS CONTROLLED BY MANUALLY
SETTINGS>>		SET VALUES PROGRAMMABLE BY USER
Language >	ENGLISH	SET THE LANGUAGE(ENGLISH, NORWEGIAN)
Time Set >	-- / -- / --	SET THE CURRENT TIME
Date Set >	-- --	SET THE CURRENT DATE
Sun RunTime1 >	--:-- / --:--	SET THE SYSTEM START TIME 1 AND STOP TIME 1 FOR SUNDAY
Sun RunTime2 >	--:-- / --:--	SET THE SYSTEM START TIME 2 AND STOP TIME 2 FOR SUNDAY
Mon RunTime1 >	--:-- / --:--	SET THE SYSTEM START TIME 1 AND STOP TIME 1 FOR MONDAY
Mon RunTime2 >	--:-- / --:--	SET THE SYSTEM START TIME 2 AND STOP TIME 2 FOR MONDAY
Tue RunTime1 >	--:-- / --:--	SET THE SYSTEM START TIME 1 AND STOP TIME 1 FOR TUESDAY
Tue RunTime2 >	--:-- / --:--	SET THE SYSTEM START TIME 2 AND STOP TIME 2 FOR TUESDAY
Wed RunTime1 >	--:-- / --:--	SET THE SYSTEM START TIME 1 AND STOP TIME 1 FOR WEDNESDAY
Wed RunTime2 >	--:-- / --:--	SET THE SYSTEM START TIME 2 AND STOP TIME 2 FOR WEDNESDAY
Thu RunTime1 >	--:-- / --:--	SET THE SYSTEM START TIME 1 AND STOP TIME 1 FOR THURSDAY
Thu RunTime2 >	--:-- / --:--	SET THE SYSTEM START TIME 2 AND STOP TIME 2 FOR THURSDAY
Fri RunTime1 >	--:-- / --:--	SET THE SYSTEM START TIME 1 AND STOP TIME 1 FOR FRIDAY
Fri RunTime2 >	--:-- / --:--	SET THE SYSTEM START TIME 2 AND STOP TIME 2 FOR FRIDAY
Sat RunTime1 >	--:-- / --:--	SET THE SYSTEM START TIME 1 AND STOP TIME 1 FOR SATURDAY
Sat RunTime2 >	--:-- / --:--	SET THE SYSTEM START TIME 2 AND STOP TIME 2 FOR SATURDAY
Weekly RunTime1 >	--:-- / --:--	SET THE SYSTEM START TIME 1 AND STOP TIME 1 FOR ALL DAYS OF THE WEEK
Weekly RunTime2 >	--:-- / --:--	SET THE SYSTEM START TIME 2 AND STOP TIME 2 FOR ALL DAYS OF THE WEEK

PressureMaxSet>	3.5	MAXIMUM ALLOWABLE PRESSURE ON FLUID SYSTEM. THE DEVICE GIVES AN ALARM WHEN THE PRESSURE EXCEEDS THE PRESET VALUE
SystemPressure>	2	IF AUTO-FILLING FUNCTION IS ACTIVE; AUTO REFILLING OPERATION STOPS AT THIS SETTING VALUE.
RefillingPressure>	1.8	IF AUTO-FILLING FUNCTION IS ACTIVE; AUTO REFILLING OPERATION STARTS AT THIS SETTING VALUE.
Fault Log Reset >		ERROR MESSAGES ARE CLEARED ON MEMORY
TotRefillingNumRst>		TOTAL REFILLING NUMBER RESET TO 0
Standby Time Set>		DESIRED STANDBY TIME IF DEGASSING IS FINISHED
Refilling Time in 12 hr>		ALLOWED REFILL TIMES IN 12H
Factory Sets>		SYSTEM IS RESTORED TO ITS FACTORY SETS

RUNNING LOGS>>		SYSTEM RUNNING TIMES
Total Period:	1234	TOTAL RUNNING PERIOD NUMBER (1 CYCLE)
Total AirVent:	123	TOTAL AIRVENT NUMBER
Total SysRun Time:	1234 hrs	TOTAL SYSTEM RUN TIME
Tot.Pump Run Time:	123 hrs	TOTAL POMP RUN TIME
TotRefillingNumber:	113	TOTAL REFILLING NUMBER

FAULT LOGS>>		ERROR MESSAGES ON MEMORY
SYSTEM INFO>>		SYSTEM TYPE AND SOFTWARE VERSION
Type	> Model	SYSTEM TYPE(V3-R, V6-R, V9-R)
Version	> 8.01	SOFTWARE VERSION

SRVC. SETTINGS>> SERVICE SET VALUES (FACTORY SETTINGS ACCORDING TO SYSTEM. END-USER CAN NOT USE THIS MENU.)

TotalMem Reset TUBE FILLING MAXIMUM TIME THE DURATION OF THE TIME OF ONE CYCLE (IT WILL BE AN ALARM OCCURRED IF THIS TIME IS EXCEEDED) ALL MEMORY LOGS RESET

TESTS>>		PUMP AND SELENOID VALVES TESTS (Manual test)
ESC	PUMP EXT	
	OFF OFF	

7. FAILURES

No water : (ER01

ViraDeg gives "no water" error if tube can't has water inside in 360 second. Please be sure the inlet line is fully open and be sure there is nothing block the water inlet.

Sensor Error : (ER02

When pressure / temperature (RPS sensor can't get any information or receive wrong information from system, it gives sensor error.

High Pressure : (ER05)

When system pressure is higher than set value, ViraDeg gives error to alert the user.



At beginning, ViraDeg will include factory setting values. Users can change and customise according to their installation.



These, error helps to pre-detect any reason (high pressure, leakage, high temp. sensor faulty, insufficient water etc) which may damage to ViraDeg or other components in the installation.

8. REMOVING CONTROLLER

This chapter explain "how to remove controller" against any failure to fix or change the controller with new unit. It helps to solve the problem very quickly and its handy against shipping back the product to manufacturer.



- If you live any problem, please contact with the company for service and do not open the controller inside to fix it your self.



- Opened box products without service permit, will be out of the product warranty.

- Please be sure that system switched off. (no electricity)

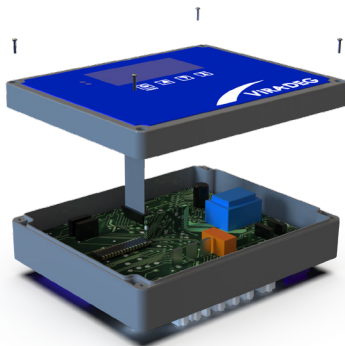

- Please do not pull mightily the surface of the box. It may damage the cables.

(Removing the 4 screws located in the box)

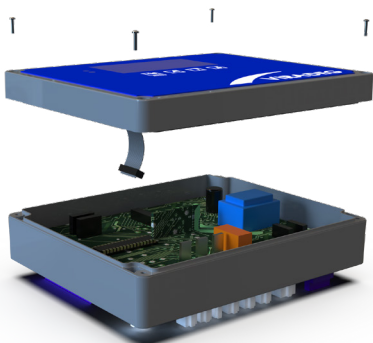

- After open the box, please remove the connected cables from sockets.

(Cable conenction removal)

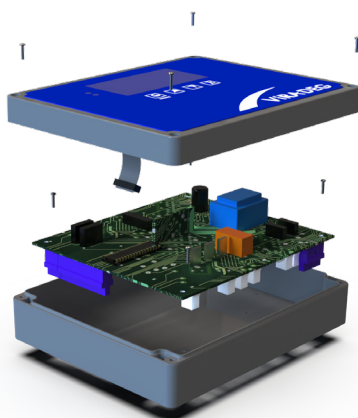

- Forward the box surface which includes buttons and smart controller card to your supplier.

9. MODBUS FUNCTIONS

Coils Regs.	Reg. Adr.			0	1
0	0	R/W	System ON/OFF	OFF	ON
1	1	R	Alarm/OK	OK	ALARM
2	2	R	Run/Off-Standby-Error	OFF/ STANDBY / ERROR	RUN
3	3	R/W	Refill ON/Refil OFF	Refill OFF	Refill ON
4	4		Reserved for future		
5	5		Reserved for future		
6	6		Reserved for future		
7	7		Reserved for future		

Holding Register	Reg. Adr.	Read & Write	Value	Examples	Explanations
40001	0	R	Temperature Value		
40002	1	R	Pressure Value	63 /10= 6,3	The read value must be divided by 10.
40003	2	R	Error Code	1 to 10	
40004	3	R	Total Period	2x1000= 2000	The read value must be multiplied by 1000
40005	4	R	Total Airvent	15x1000= 15000	The read value must be multiplied by 1000
40006	5	R	Total System Run Time		
40007	6	R	Total Pump Run Time		
40008	7	R	Total Refilling Number		
40009	8	R/W	Time Set	1745 = 17:45	
40010	9	R/W	the Day set	day of the month	
40011	10	R/W	the Month set	month of the year	
40012	11	R/W	Year set	year	
.			N/A		
40021	20	R/W	Language Set	0:EN, 1:NO	
40022	21	R/W	Pressure Max Set	45/10= 4,5	The read value must be divided by 10.
40023	22	R/W	Refill Pressure High Set	30/10= 3,0	The read value must be divided by 10.
40024	23	R/W	Refill Pressure Low Set	7 /10= 0.7	The read value must be divided by 10.
40025	24	R/W	Refill Max Number		
40026	25	R/W	Temperature High Set		
40037	26	R/W	Temperature Low Set		
40028	27	R/W	Standby Time Set		
40029	28	R/W	Refill Times in 12 Hrs.		

Error Codes	
Sensor error	1
No Water	2
	3
	4
High Pressure	5

Languages	
English	0
Norwegian	1
Finnish	2
Turkish	3
Italian	4



MODBUS system does not able to read any punctuation marks therefore the set value should be described like our examples.

MODBUS PROTOCOL

Modbus Protocol Formats:

Byte Format:

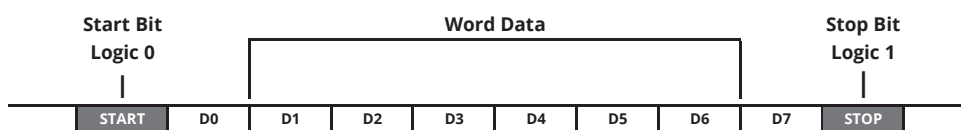

Master Request Frame:

Address	Function code	Start Address		Quantity Of Registers		CRC	
1 Byte	1 Byte	1 Byte	1 Byte	1 Byte	1 Byte	1 Byte	1 Byte

Answer frame:

Address	Function code	Byte Count	Quantity Of Registers		CRC	
1 Byte	1 Byte	1 Byte	1 Byte	1 Byte	1 Byte	1 Byte

Each slave devices in a network is assigned a unique unit address from 1 to 247. (Selectable from menu)

Baud Rate Table: (Selectable from menu)

0	1200
1	2400
2	4800
3	9600
4	19200

9.1 ViraDeg Modbus Connection

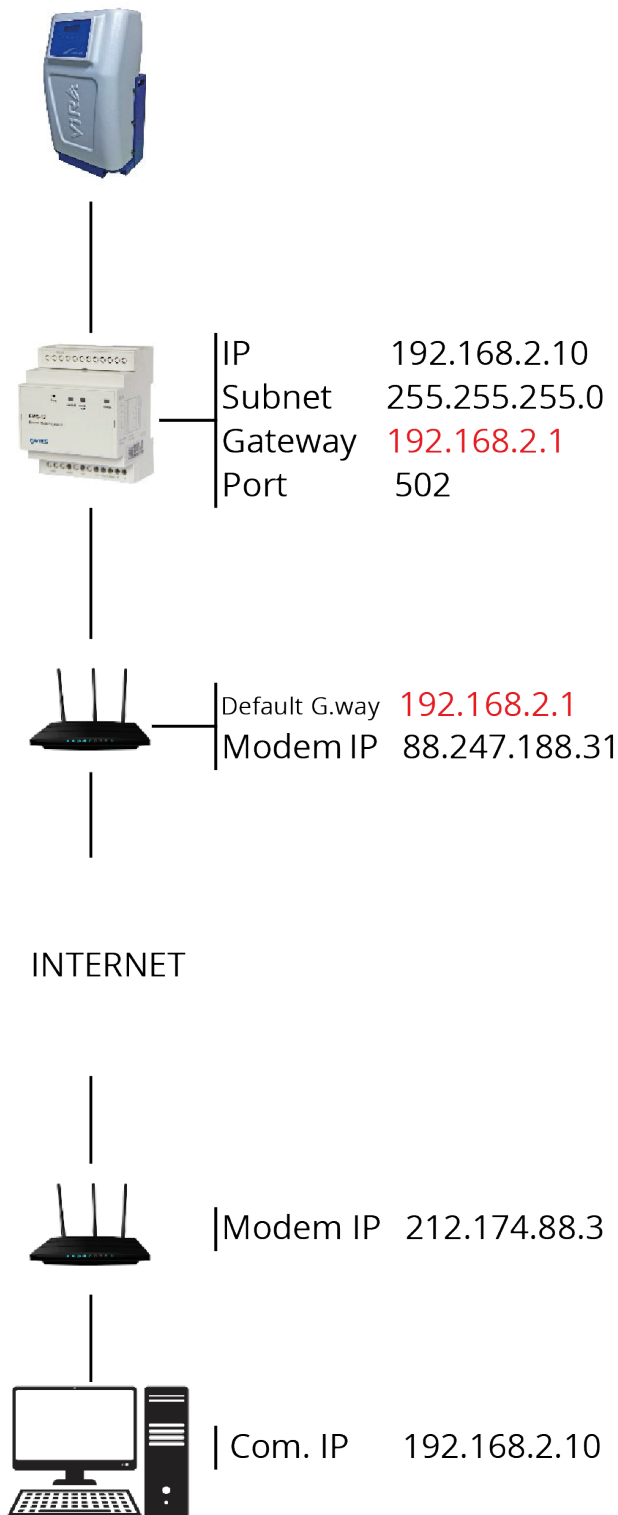

In this example, an application shows how you can access ViraDeg which are connected to a remote network using Ethernet-MODBUS Gateway. The program in this example runs on a computer with an IP address of 192.168.2.12 and the placed device on the remote network under the sub-net with an IP address of 88.247.188.31. To enable to access to MODBUS Gateway from the remote network, necessary routing configurations on the modem to which the gateway is connected must be made. Furthermore, the default gateway address on the device must be entered as the LAN address of the installed ADSL modem, which is 192.168.2.1.

The model of the ADSL modem used in this application is AirTies ADSL. Many modems available on the market are configured using a WEB interface. To change the configuration of your modem, enter the IP address of your modem (88.247.188.31 in this example) to the address bar of your preferred browser. You will be greeted with the Main Menu.

After you write your username and password please enter to reach your modem settings.

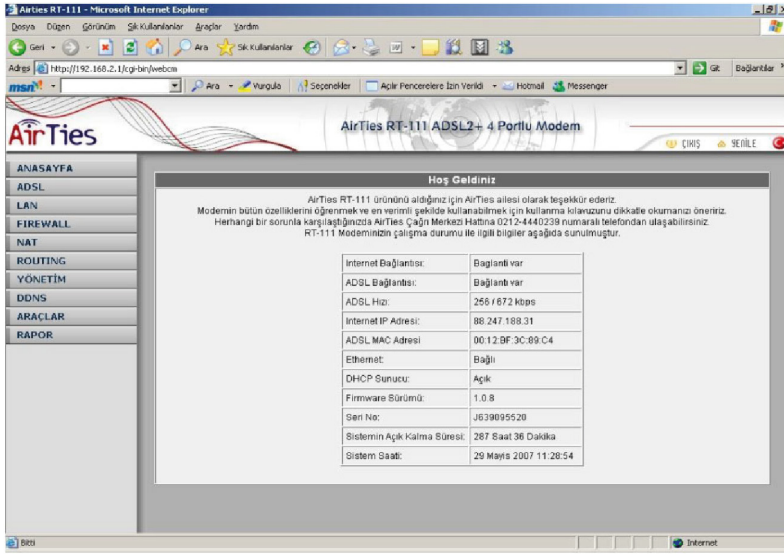

Then, please select NAT MENU from left side of the screen and activate this option.

Select Port Forwarding under the NAT Menu and add your device to the port forwarding and add your device to the port forwarding list. After you save the changes you will be list. After you save the changes you will be able to monitor the serially connected devices over the internet.

Example as below ;

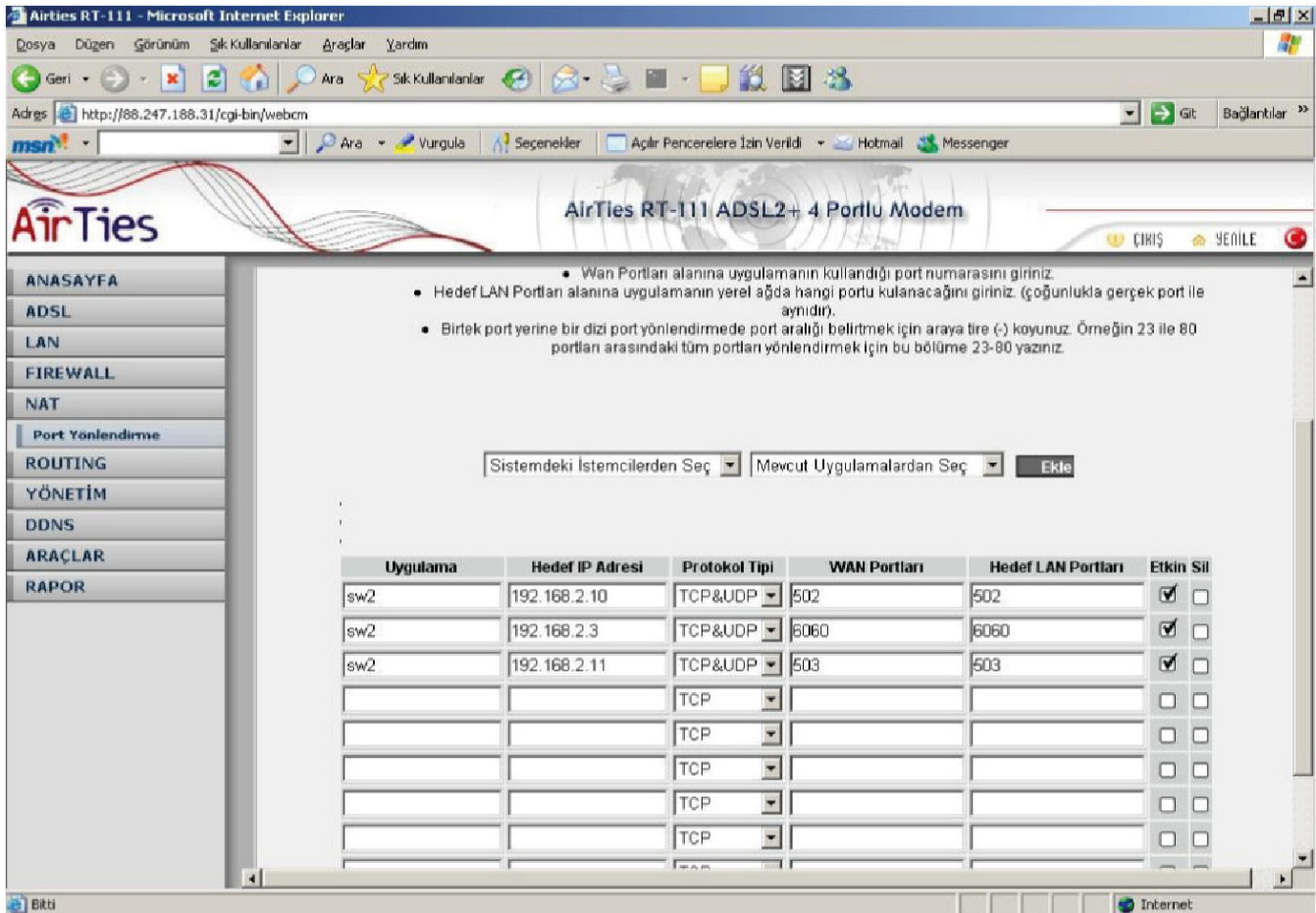

Reading/Changing The Configuration Using The WEB Interface

Using the port 80 of the HTTP protocol on the gateway, you can access the device settings from a remote computer. The only option you can not change using the WEB interface is the "Disable Web Access" option.

1st. enter the IP address of your device to the address bar of your preferred browser. If you are connecting from an outside network, enter the IP address of your modem. In this case, the port 80 on the modem must be forwarded to the IP address of the device.

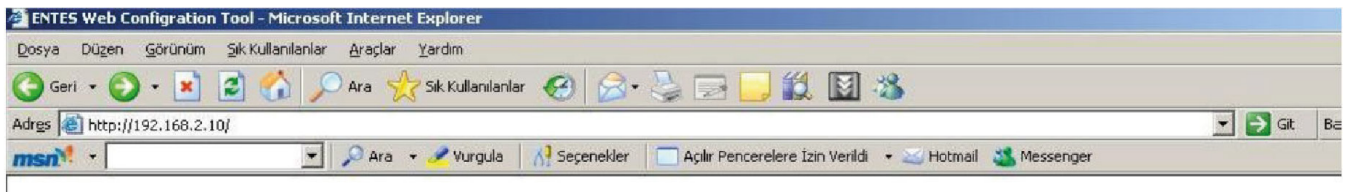

2nd. You will be asked to enter a password to access the System Settings.

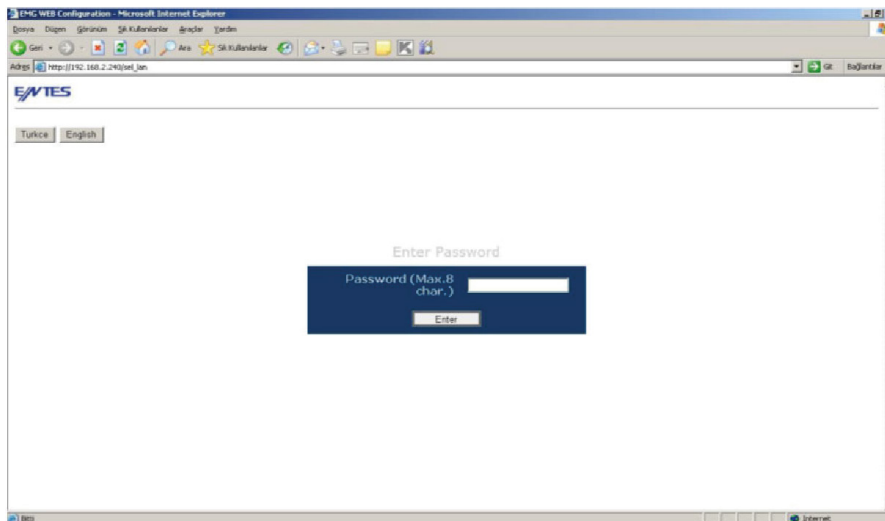

3rd. If you entered the correct password, you will be directed to the settings page. If you enter a wrong password, you will be asked to enter the correct password again.

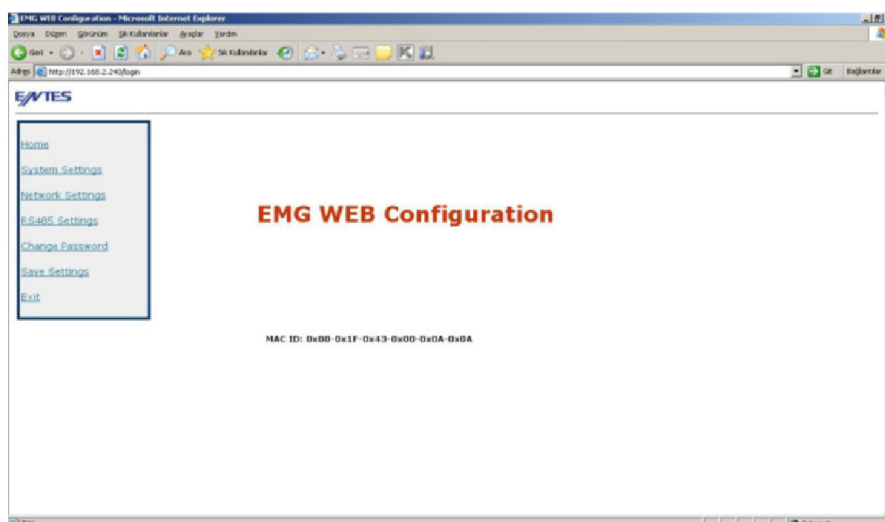

4th. After you made the desired setting changes, click on the UPDATE button. To install the settings that you made, click on the "Save Changes" button. The EMG will reset and your new settings will be activated.

MOD-BUS Poll Program Settings

Please download "MODBUS Poll" program with accepting allowings. Then reach the following screen.

First, find the "Connect (F3)" with "Connection" on the Menu.

Then, we should select connection type as below and IP Address must be written. Requested IP Address must be given to you from ViraDeg user. This is internet IP address.

After you did everything correct, new page will be opened and you will see some values. You can check this values meanings in following page.

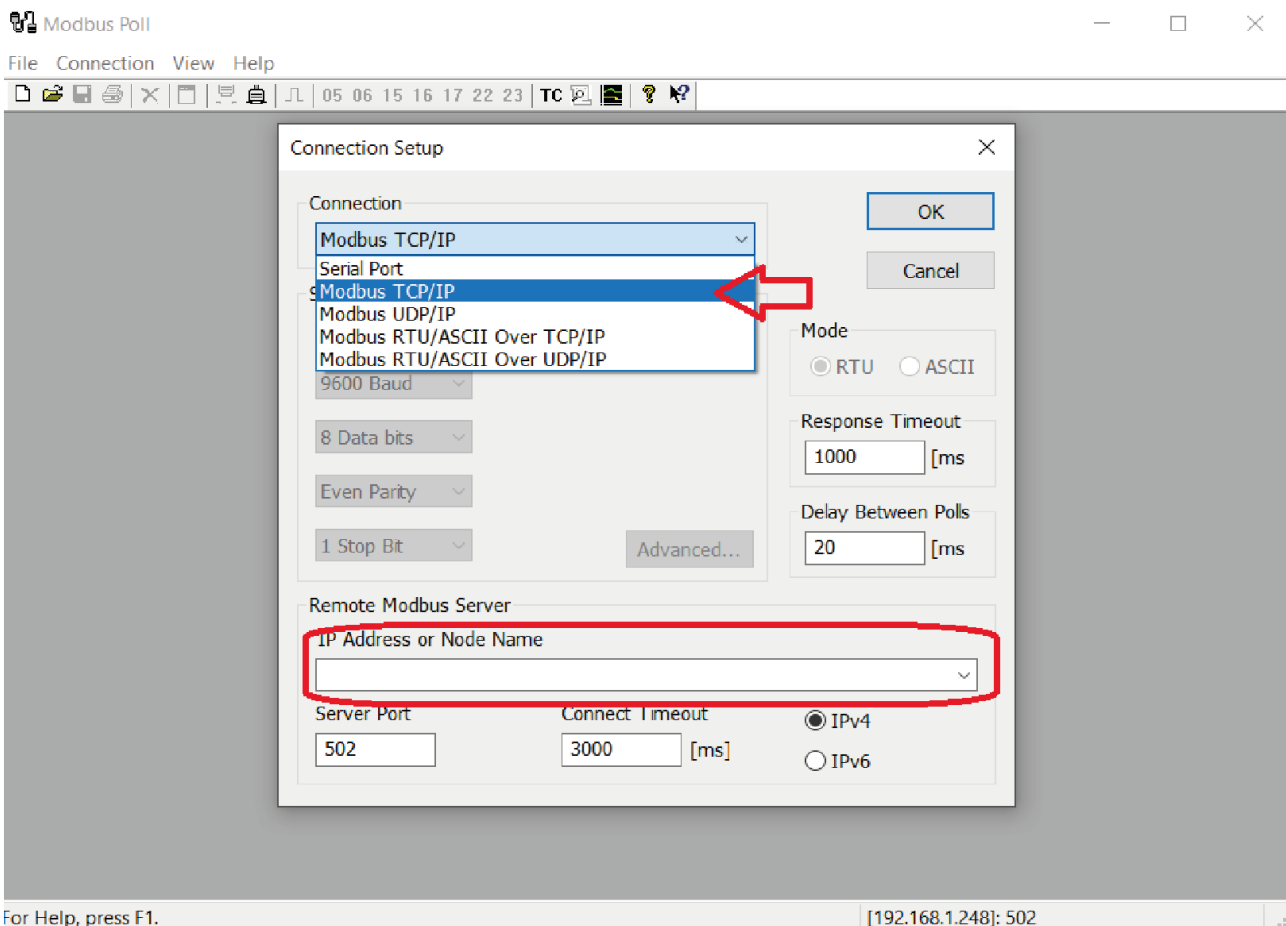
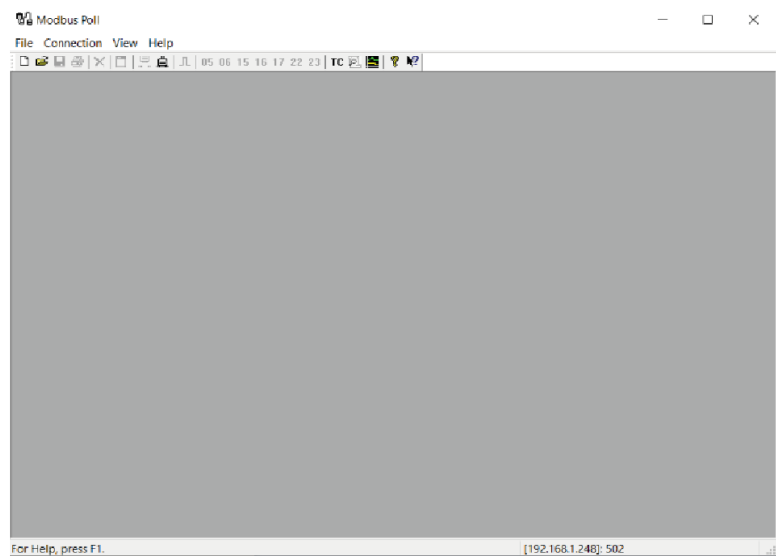

For Help, press F1.

[192.168.1.248]: 502

If you receive time-out problem please check your "Read/Write Definition" from SETUP menu.

If already has same settings as shown this picture probably you have Vira's 2019 production models.

In this case, we are not able to see all column (10) at the same time. Please change your settings as following picture.

Read/Write Definition

Slave ID: OK

Function: Cancel

Address mode
 Dec Hex

Address: PLC address = 40001

Quantity:

Scan Rate: [ms] Apply

Disable
 Read/Write Disabled
 Disable on error Read/Write Once

View
 Rows
 10 20 50 100 Fit to Quantity
 Hide Name Columns PLC Addresses (Base 1)
 Address in Cell Enron/Daniel Mode

Request
 RTU
 ASCII

Read/Write Definition

Slave ID: OK

Function: Cancel

Address mode
 Dec Hex

Address: PLC address = 40001

Quantity:

Scan Rate: [ms] Apply

Disable
 Read/Write Disabled
 Disable on error Read/Write Once

View
 Rows
 10 20 50 100 Fit to Quantity
 Hide Name Columns PLC Addresses (Base 1)
 Address in Cell Enron/Daniel Mode

Request
 RTU
 ASCII

Even you believe did everything as described but couldn't reached your unit. Please contact with us for support.

10. TRANSPORT

The shipping papers list all the items, such as equipment and documentation. Ensure that the delivery is complete and not damaged. The automat is packed vertical on disposable pallets and are fully assembled.

Identify the items that are missing or not correctly delivered. Read the general terms and conditions in the shipping papers.

- Transport the pallets vertically.
- Lift the automat just slightly.



Make sure that the lifting device can support the automat. For weight and dimensions, refer to chapter 3 : Technical Specifications.

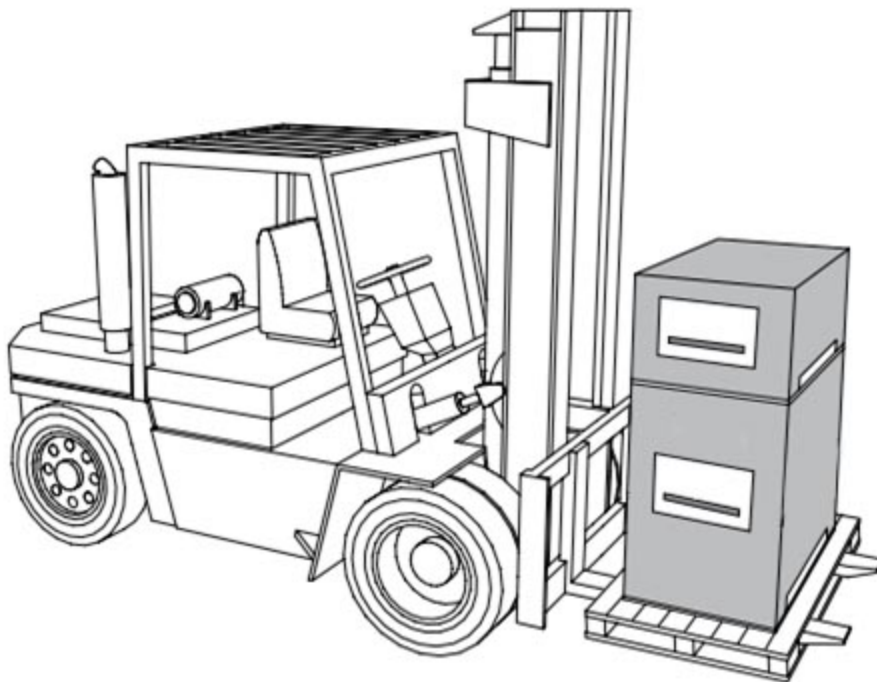

Vira does not recommend stacking the products.

11. GUARANTEE

- The guarantee for this product is valid until 2 years following the purchasing date.
- The guarantee lapses in cases of faulty installation, incompetent use and/or non authorised personnel trying to make repairs.
- Consequential damage is not covered by the guarantee.
- Normal tear and wear is excluded by the guarantee.

12. CE STATEMENT

12.1 Declaration of conformity

ORIGINAL

EC Declaration of Conformity

The manufacturer :

Vira Isı ve Endüstriyel Ürünler A.S.
İkitelli OSB, Metal İş Sanayi
11.Blok No.37-39 Basaksehir
34306 Istanbul / Türkiye
declares that the vacuum degassers :

ViraDeg
Type : V3 / V3-R / V6 / V6-R / V9 / V9-R

are in compliance with all relevant demands of following European Directives :

- Machine Directive 2006 / 42 / EC
- Low Voltage Directive 2006 / 95 / EC
- EMC Directive 2004 / 108 / EC

Istanbul , Jan 24th , 2020



A.Mecit Cengiz
Founder

VİRA ISI VE ENDÜSTRİYEL ÜRÜNLER A.Ş.
Metal İş Sanayi Sitesi 11.Blok No:37-39 İkitelli / İstanbul
Tel: +90.212.549 57 70 Fax: +90.212.549 58 48
www.viraisi.com info@viraisi.com

The manufacturer reserves the right to make change without prior notification.

Information given in this brochure may not be reproduced complete or in part without the prior written consent of Vira Co.

VİRA ISI VE ENDÜSTRİYEL ÜRÜNLER A.Ş

Metal İş Sanayi Sitesi 11.Blok No:37-39 İkitelli/İstanbul

Tel: +90 212 549 57 70

Fax: +90 212 549 58 48

www.viraisi.com

info@viraisi.com

